

Encoder A = Front encoder
Encoder B = Rear encoder

Encoder A is specified by this data-sheet.

Encoder B can be any 58 mm encoder, incremental or absolute, with 61 clamping flange and ø10 mm shaft.

Specify encoder B from RSI 500-series or RSA 500/600-series and observe that the selected encoder type may determine the overall technical specification of the RSD 525.

Short description:

- >> 6 short-circuit protected outputs
- >> IP 67 at housing, IP 66 at shaft inlet
- >> 5 Vdc or 9...30 Vdc
- >> Robust housing for harsh environment
- >> Shock and vibration protected
- >> Possible combinations incremental – incremental or incremental – absolute

Suitable applications:

- >> Standard to demanding industrial applications
- >> Safety application with redundant feedback

General information

Encoder data		
Type	RSD 525	
Operating temperature	-40°C .. +70°C	
Storage temperature	-30°C .. +70°C	
Ingress protection class	IP-67 according to IEC 60529	
At shaft inlet	IP-66 according to IEC 60529	
Vibration (55 to 2000Hz)	< 300 m/s ² according to IEC 60068-2-6 ⁽¹⁾	
Shock (6ms)	< 2000 m/s ² according to IEC 60068-2-27	
Cover material	Aluminium	
Cover surface treatment	Coated and cromated or anodized	
Weight	Approx. 600g	
Accuracy and resolution		
Line count	1..5000 ppr	5001..10 000 ppr
Dividing error	± 50 °el	± 90 °el
Channel separation	90 ± 25 °el	90 ± 45 °el
Measuring steps	4 x Line count	
Requirements of Encoder B		
Shaft	ø10ro	
Flange	61 Clamping flange	

Flange option

Flange type	51, LL58	63, Synchro	61, Clamping	52, LL68
Outer diameter	ø58 mm	ø58 mm	ø58 mm	ø68 mm
Mounting holes	3 x M3 & 3 x M4	3 x M4	3 x M3	3 x M3 & 3 x M4
Flange material	Aluminium	Aluminium	Aluminium	Aluminium
Surface treatment	Anodized	Anodized	Anodized	Anodized

Shaft option

Shaft type	Ø6 round	Ø6 with face	Ø10 round	Ø10 with face
Axial shaft load	50 N	50 N	50 N	50 N
Radial shaft load	60 N	60 N	60 N	60 N
Mech. permissible speed	6000 rpm (12 000)	6000 rpm (12 000)	6000 rpm (12 000)	6000 rpm (12 000)
Shaft material	Stainless steel	Stainless steel	Stainless steel	Stainless steel
Moment of inertia	4,6 x 10 ⁻⁶ kgm ²	4,6 x 10 ⁻⁶ kgm ²	4,6 x 10 ⁻⁶ kgm ²	4,6 x 10 ⁻⁶ kgm ²

⁽¹⁾<150m/s² on encoders with connectors



Connection option

Connector type	Cable	8 pin M12
Function	Colour	PIN
S00	Yellow	4
S00 inverted	Black	5
S90	Green	3
S90 inverted	White	1
Sref	Brown	2
Sref inverted	Violet	6
+E Volt	Red	8
0 Volt	Blue	7
STATUS	Grey	NA
Housing	Shield	Chassis
Connecting direction		
Radial	Yes	Yes

NA=Not Available

Electrical option

Power supply	5 V ±10%	9-30 V	
Polarity protected	No	Yes	
Output signals	TTL ¹	HTL	RS-422
Short circuit protected	Yes	Yes	Yes
Current consumption	45 mA	50 mA at 24Vdc	25 mA at 24Vdc
Max consumption	75 mA	75 mA	40 mA
Output load (max)	±20 mA	±40 mA	±20 mA
Output frequency (max)	300 kHz	300 kHz	300 kHz
U _{high} at 10mA load	> 3.0 V	> +EV - 2.0 V	> 3.0 V
U _{low} at 10mA load	< 0.4 V	< 1.15 V	< 0.4 V
Cable length (max)	50 m	200 m @ 50 kHz	1 km (TIA/EIA-422-B)
STATUS output	Yes	Yes	Yes
High level	Encoder OK	Encoder OK	Encoder OK
Low level	Warning/Failure	Warning/Failure	Warning/Failure

¹TTL output comply to the RS-422 standard when differential transmission is used

Output circuit

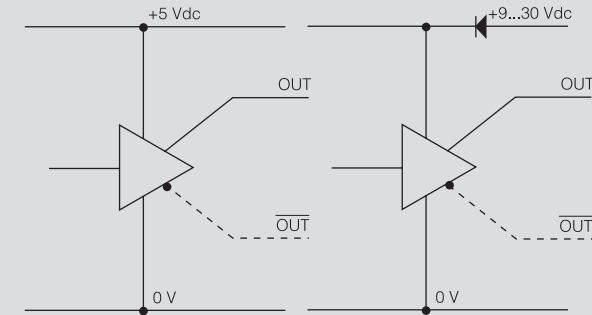

Output signals

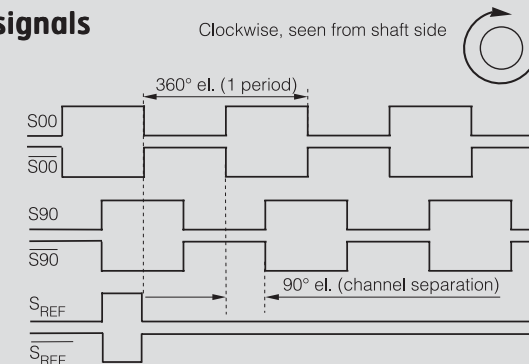

Status outputs

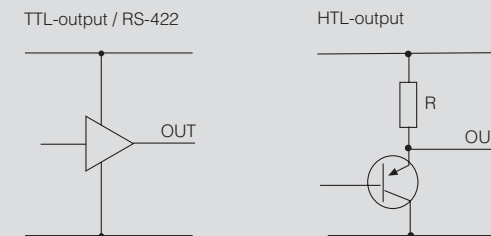

Dimensions

Encoder B

Encoder A

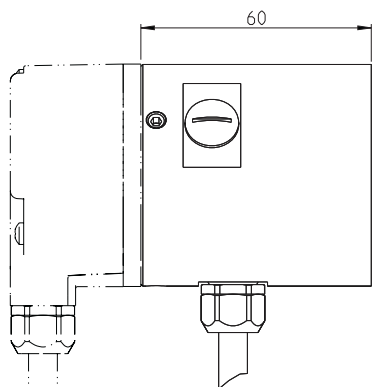

Total length of the RSD 525 encoder is determined by encoder B. Please advice appropriate datasheet for additional dimensions of encoder B.

Flanges

51, LL58

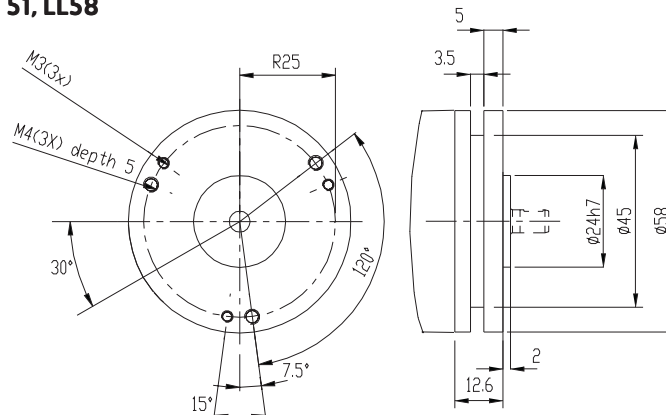

63, Synchro

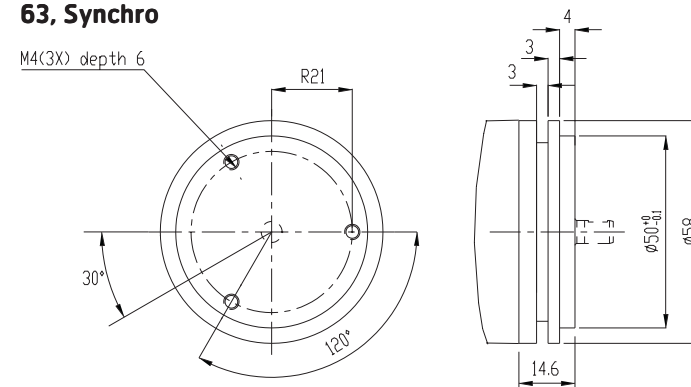

61, Clamping

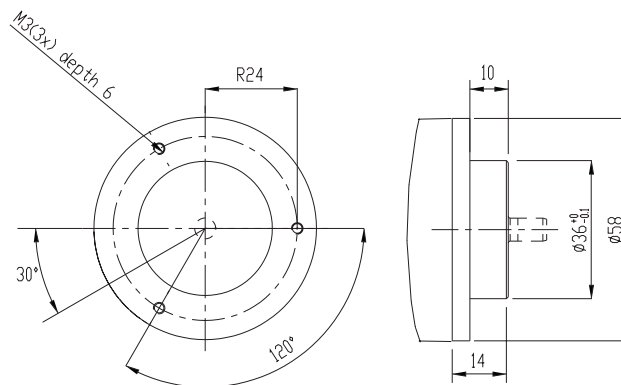

52, LL68

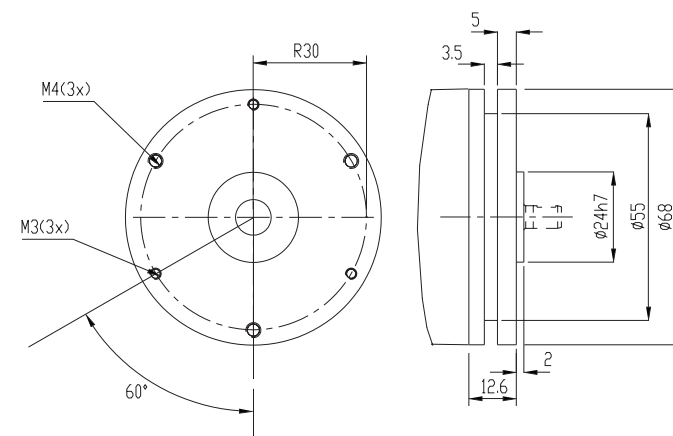

Connectors

Cable
5x2x0,25 shielded

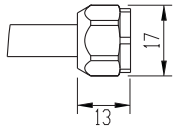

8pin M12

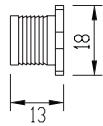

Shafts

6 mm with face

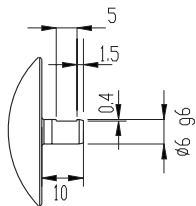

6 mm round

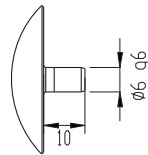

10 mm with face

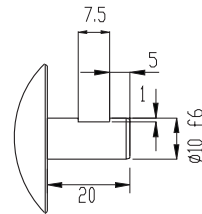

10 mm round

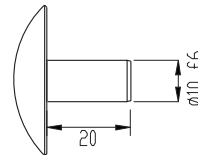

Various combinations/examples

RSD 525 63

6 mm, radial cable with
25 bit PROFIBUS

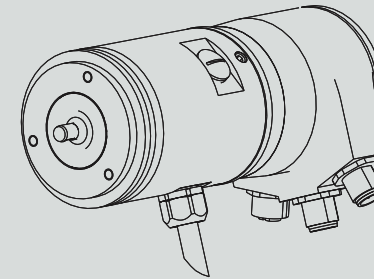

RSD 525 52

10 mm, radial cable with
incremental encoder

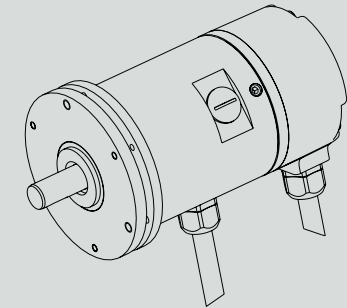

Ordering information Tick your choice

Type	RSD 525			
Flange	51, LL58	63, Synchro	61, Clamping	52, LL68
Shaft	Ø6 round	Ø6 with face	Ø10 round	Ø10 with face
Electronics ⁽¹⁾	Supply	5Vdc	9-30Vdc	
	Output	TTL	HTL	RS-422
Connection	Cable	8 pin M12		
Connecting direction	Radial	Radial		
Line count	1..5000	5001..10 000		
Encoder B	Provide part number or product designation when ordering			

⁽¹⁾ Possible combinations: 5Vdc/TTL, 9-30Vdc/HTL or 9-30Vdc/RS-422

Please, specify line count and cable length when ordering

Ordering example: Encoder A: RSD 525 63 Ø6wf 5Vdc 1024ppr TTL 8 pin M12 Radial

Encoder B: By specifying the required encoder unique Part Number or Designation as:
456123-01 or RSI 503 61 Ø10ro 9-30Vdc 512ppr HTL Cable Radial